

Extra High Capacity Multi-Bag Filters

These multi-bag filters offer a wide range of flow capacities and contaminant holding capabilities. They contain from 2 to 23 baskets, all the same size. They are fitted with perforated stainless steel baskets designed to hold disposable or cleanable filter bags. Industry standard size bags are used: the standard 30-inch baskets take bag size 2, and optional 15-inch baskets take size 1. The standard pressure rating for all models is 150 psi. All housings can be supplied with a ASME code stamp, if required. For filter flows to 2300 gpm with a 150 psi rated housing, use the pre-selected ordering code listed on the next page.

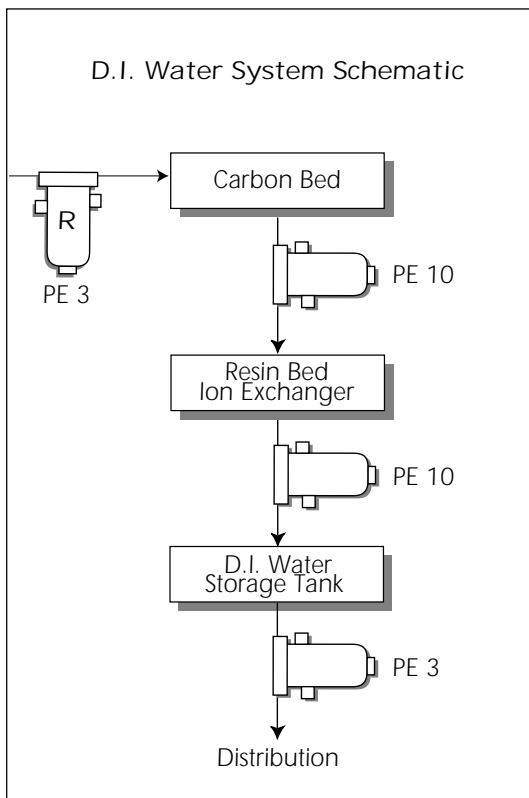

Typical Application



Water Flow Rates with 10m Filter Bags

Model	GPM
16	200
18	300
22	400
24	600
30	800
36	1200
42	1700
48	2300

